

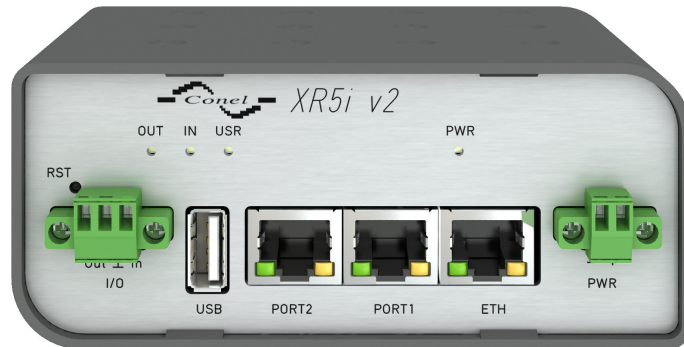

A **B&B ELECTRONICS** Company

# Industrial router **XR5i v2**

## USER'S MANUAL



## Used symbols



*Danger* – important notice, which may have an influence on the user's safety or the function of the device.



*Attention* – notice on possible problems, which can arise in specific cases.



*Information, notice* – information, which contains useful advice or special interest.

## GPL license

Source codes under GPL license are available free of charge by sending an email to:

[info@conel.cz](mailto:info@conel.cz).



# Contents

<b>1</b>	<b>Safety instruction</b>	<b>1</b>
<b>2</b>	<b>Product disposal instructions</b>	<b>2</b>
<b>3</b>	<b>Router description</b>	<b>3</b>
<b>4</b>	<b>Contents of package</b>	<b>4</b>
<b>5</b>	<b>Router design</b>	<b>5</b>
5.1	Router versions . . . . .	5
5.2	Delivery identification . . . . .	5
5.3	Ordering codes . . . . .	6
5.4	Basic dimensions of plastic box . . . . .	7
5.5	Basic dimensions of metal box . . . . .	7
5.6	Mechanical dimensions and mounting recommendations . . . . .	8
5.7	Removing from the DIN rail . . . . .	10
5.8	Description of the front panel . . . . .	11
5.8.1	Status indication . . . . .	12
5.8.2	Power connector PWR . . . . .	13
5.8.3	Ethernet port . . . . .	14
5.8.4	PORT1 . . . . .	16
5.8.5	PORT2 . . . . .	16
5.8.6	USB Port . . . . .	17
5.8.7	I/O Port . . . . .	18
5.8.8	Reset . . . . .	20
<b>6</b>	<b>First use</b>	<b>21</b>
6.1	Connecting the router before first use . . . . .	21
6.2	Start . . . . .	22
6.3	Configuration . . . . .	22
6.3.1	Configuration over web browser . . . . .	22
6.3.2	Configuration over Telnet . . . . .	22
<b>7</b>	<b>Technical parameters</b>	<b>23</b>
7.1	Technical parameters of router . . . . .	23
7.2	Technical parameters of processor . . . . .	23
7.3	Technical parameters I/O port . . . . .	24
7.4	Technical parameters of expansion port . . . . .	24

<b>8 Recommended literature</b>	<b>25</b>
<b>9 Possible problems</b>	<b>26</b>
<b>10 FAQ</b>	<b>27</b>
<b>11 Customers support</b>	<b>29</b>

# List of Figures

1	Contents of package . . . . .	4
2	Front panel XR5i v2F . . . . .	5
3	Front panel XR5i v2F SL . . . . .	5
4	Label XR5i v2F . . . . .	5
5	Label XR5i v2F SL . . . . .	5
6	Basic dimensions of plastic box . . . . .	7
7	Basic dimensions of metal box . . . . .	7
8	Cable routing . . . . .	8
9	Cable routing for SL version . . . . .	8
10	Space in front of connectors . . . . .	9
11	Space in front of connectors – SL . . . . .	9
12	Default position of DIN holder . . . . .	10
13	Removing from the DIN rail . . . . .	10
14	Front panel XR5i v2F . . . . .	11
15	Front panel XR5i v2F SL . . . . .	11
16	Power connector . . . . .	13
17	Connection of power supply connector . . . . .	13
18	Connection of power supply . . . . .	13
19	Ethernet connector . . . . .	14
20	Connection of ethernet cable . . . . .	14
21	Example of router connection . . . . .	15
22	PORT1 cable connection . . . . .	16
23	PORT2 cable connection . . . . .	17
24	USB connector . . . . .	17
25	Connection PLC to the router . . . . .	18
26	Connection flash memory to the router . . . . .	18
27	I/O connector . . . . .	18
28	Connection of I/O cable . . . . .	19
29	Connection of input and output to the router . . . . .	19
30	Router reset . . . . .	20
31	Router connection . . . . .	21

# List of Tables

1	Router versions . . . . .	5
2	Delivery identification . . . . .	5
3	Ordering codes . . . . .	6
4	Front panel description . . . . .	11
5	Router status indication . . . . .	12
6	Connection of power connector . . . . .	13
7	Connection of Ethernet connector . . . . .	14
8	Connection of USB connector . . . . .	17
9	Connection of I/O port . . . . .	18
10	Description of reset and restart router . . . . .	20
11	Technical parameters of router . . . . .	23
12	Technical parameters of processor . . . . .	23
13	Technical parameters I/O port . . . . .	24

# 1. Safety instruction



***Please, observe the following instructions:***

- The router must be used in compliance with all applicable international and national laws and in compliance with any special restrictions regulating the utilization of the router in prescribed applications and environments.
- To prevent possible injury to health and damage to appliances and to ensure that all the relevant provisions have been complied with, use only the original accessories. Unauthorised modifications or utilization of accessories that have not been approved may result in damage to the router and in a breach of applicable regulations. Unauthorized modifications or utilization of accessories that have not been approved may result in the termination of the validity of the guarantee.
- The router can not be opened.
- It must not be exceeded by the maximum voltage 30 V DC power connector on the router.
- Do not expose the router to extreme ambient conditions. Protect the router against dust, moisture and high temperature.
- The router should not be used at petrol stations of flammable and explosive materials. We remind the users of the duty to observe the restrictions concerning the utilization of radio devices at petrol stations, in chemical plants, or in the course of blasting works in which explosives are used.
- When using the router in the close proximity of personal medical devices, such as cardiac pacemakers or hearing aids, you must proceed with heightened caution.
- If it is in the proximity of TV sets, radio receivers and personal computers, the telephone may cause interference.
- It is recommended that you should create an appropriate copy or backup of all the important settings that are stored in the memory of the device.

# 2. Product disposal instructions

The WEEE (Waste Electrical and Electronic Equipment: 2002/96/EC) directive has been introduced to ensure that electrical/electronic products are recycled using the best available recovery techniques to minimize the impact on the environment. This product contains high quality materials and components which can be recycled. At the end of it's life this product **MUST NOT** be mixed with other commercial waste for disposal. Check the terms and conditions of your supplier for disposal information.

## 3. Router description

Industrial router XR5i v2 is used to a secure connection between two local area networks (LANs) via two ETHERNET interfaces 10/100 and secured tunnel (IPSec, OpenVPN or L2TP). The second option is to use this router for connecting two devices with different serial interface (RS232, RS485, MBUS) alternatively I/O to the local network (LAN). In this configuration, the communication device has an ETHERNET 10/100 and two interfaces that are equipped on the user's request.

XR5i v2 router is standardly equipped with one ETHERNET 10/100 port, one USB A (host) port, one I/O port and two expansion ports. Users can select a second ETHERNET 10/100 port, serial interface RS232/RS485/RS422/MBUS, expansion port with SD card (SDH) or other inputs/outputs (I/O). Industrial XR5i v2 router is supplied either in a plastic or metal casing, based on the requirements of the customer.

Configuration is performed via web interface and protected by password. The router supports creation of VPN tunnels using technologies IPsec, OpenVPN and L2TP to ensure safe communication. Web interface provides detail statistics about the router activities.

Other diagnostic functions ensuring continuous communication include automatic functionality inspection, or hardware Watchdog which monitors the status of the router. With the help of a special window (start up script window) you may insert Linux scripts for various actions. For some applications the key option to create several different configurations for one wireless router, the so-called profiles (maximum of 4), and the option to switch between them (for example via binary input status, web interface, etc.) is essential.

The industrial router XR5i v2 has implemented SNMP protocol for remote management. It is also possible to configure the network in bulk and use any additional software - VPN SmartCluster configurator to easily configure a VPN or a program for monitoring routers in the network R-SeeNet. Industrial XR5i v2 router is enhanced by the ability to create custom functions easy integration of custom software modules.



### Examples of possible applications

- security system
- monitoring
- vending and dispatcher machines

## 4. Contents of package



Basic delivered set of router includes:

- router,
- power supply,
- crossover UTP cable,
- clip for the DIN rail,
- installation CD containing instructions,
- paper start guide.



Figure 1: Contents of package

Note: The router box and DIN mount are supplied in a metal case in the SL version.



The router can also be supplied as expansion accessories:

- Two expansion ports: RS232, RS485/422, MBUS, ETHERNET, CNT, WIFI, WMBUS or SDH. Separation columns for mounting expansion boards are included.

# 5. Router design

## 5.1 Router versions

XR5i v2 router is supplied in the following versions:

	Box	I/O	USB	PORT1	PORT2	ETH
XR5i v2F	Plastic	✓	✓	✓	✓	✓
XR5i v2F SL	Metal	✓	✓	✓	✓	✓

Table 1: Router versions

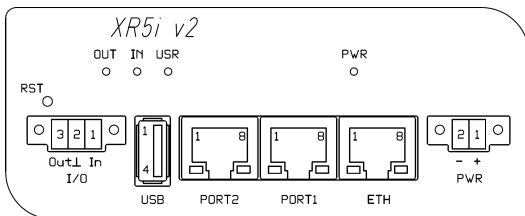

Figure 2: Front panel XR5i v2F

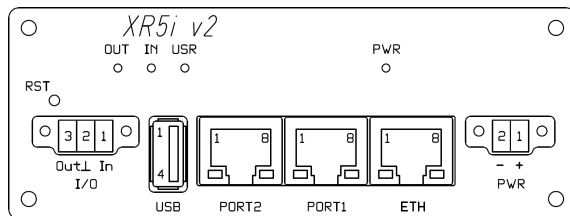

Figure 3: Front panel XR5i v2F SL

## 5.2 Delivery identification

Trade name	Type name	Other
XR5i v2F	XR-5i-v2	Full version
XR5i v2F SL	XR-5i-v2	Full version in the metal box

Table 2: Delivery identification

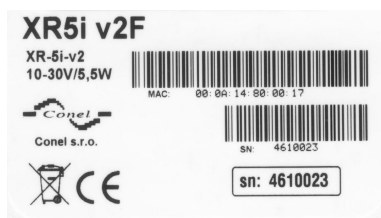

Figure 4: Label XR5i v2F



Figure 5: Label XR5i v2F SL

### 5.3 Ordering codes

Expansion port	Possible participation	Ordering code
Version without expansion port		XR5i v2F set
Version with Ethernet expansion port	PORT1	XR5i v2F ETH set
Version with RS232 expansion port	PORT1 a PORT2	XR5i v2F RS232 set
Version with RS485 expansion port	PORT1 a PORT2	XR5i v2F RS458 set
Version with MBUS expansion port	PORT1 a PORT2	XR5i v2F MBUS set
Version with CNT expansion port	PORT1	XR5i v2F CNT set
Version with WIFI expansion port	PORT2	XR5i v2F WIFI set
Version with WMBUS expansion port	PORT2	XR5i v2F WMBUS set
Version with SDH expansion port	PORT2	XR5i v2F SDH set

Table 3: Ordering codes

Second expansion port is written after first expansion port in the ordering code.

Example:

- Full version with Ethernet and RS232 port: **XR5i v2F ETH RS232 set.**
- Full version with Ethernet and RS232 port in metal cover:  
**XR5i v2F ETH RS232 SL set.**

### 5.4 Basic dimensions of plastic box

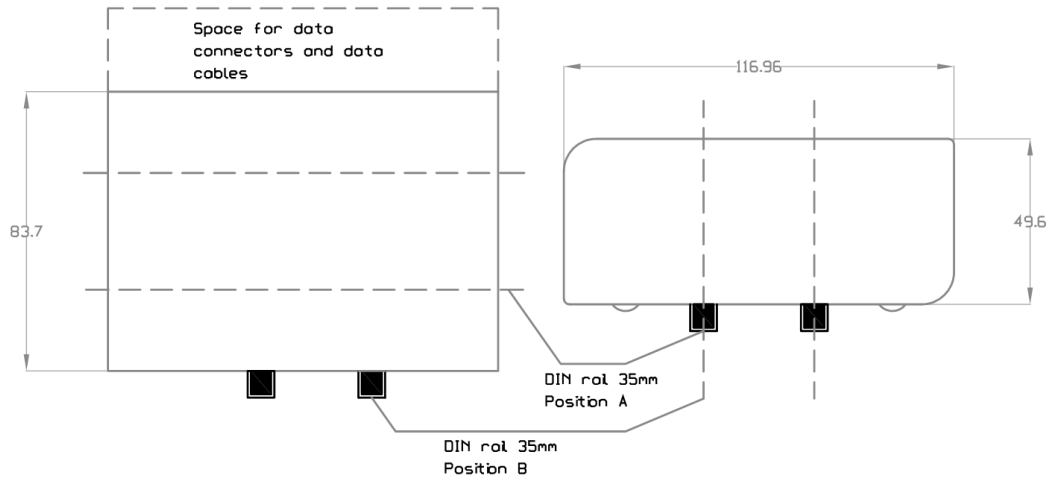

Figure 6: Basic dimensions of plastic box

### 5.5 Basic dimensions of metal box

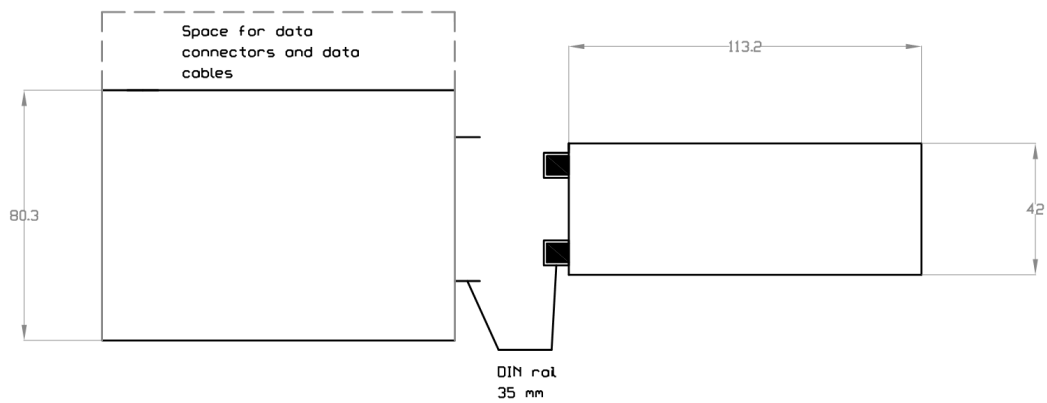

Figure 7: Basic dimensions of metal box

### 5.6 Mechanical dimensions and mounting recommendations



Mounting recommendations:

- possibility to be put on a work surface,
- DIN rail with clips CKD2 (ELPAC clip SL for metal version) are included.

For the most of applications with a built-in router in a switch board it is possible to recognize two kinds of environments:

- no public and industry environment of low voltage with high interference,
- public environment of low voltage without high interference.

For both of these environments it is possible to mount router to a switch board, the following there is no need to have examination immunity or issues in connection with EMC according to EN 60439-1 ed.2:00 + A1:04.

For compliance of EN 60439-1 ed.2:00 + A1:04 specification it is necessary to observe next assembly of the router to the switch – board:



- For every cables we recommend to bind the bunch according to the following picture, we recommend for this use:
  - Length of the bunch (combination of power supply and data cables) can be maximum 1,5 m. If the length of data cables exceeds 1,5 m or in the event of, the cable leads towards the switch – board. We recommend installing over – voltage protectors (surge suppressors).
  - With data cables they mustn't carry cables with reticular tension  $\sim 230$  V/50 Hz.
  - All signals to sensors must be twisted pairs.

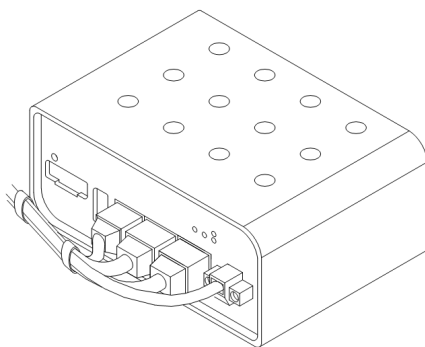

Figure 8: Cable routing

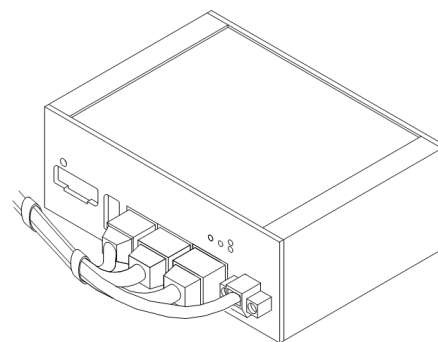

Figure 9: Cable routing for SL version

- ! Sufficient space must be left before individual connectors for handling of cables,

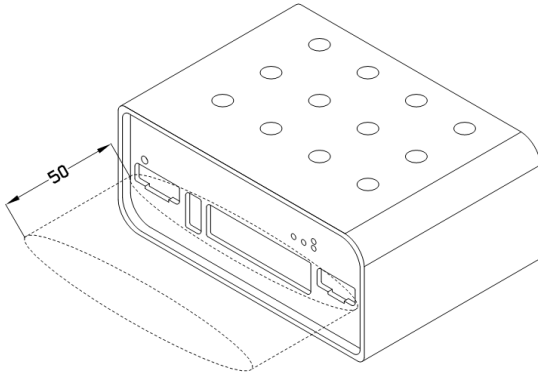

Figure 10: Space in front of connectors

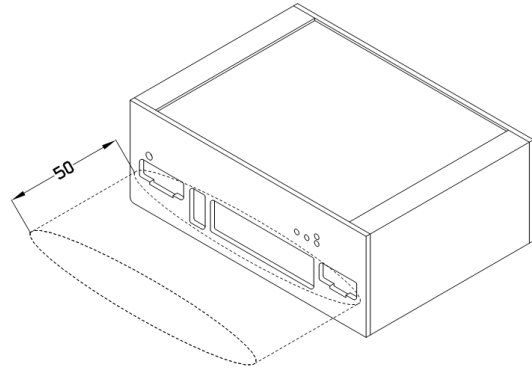

Figure 11: Space in front of connectors – SL

- ! For correct function of the router we recommend to use in the switch-board earth-bonding distribution frame for grounding of power supply of router, data cables and antenna.

### 5.7 Removing from the DIN rail

Default position of CPD2 holder (or CKD2 holder for SL version), which is used for mounting the router on a DIN rail, is shown in the following figure:

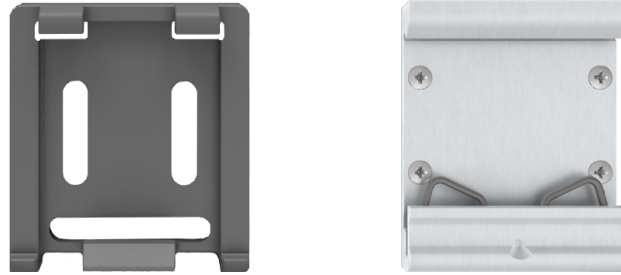

Figure 12: Default position of DIN holder

For removing from the DIN rail it is necessary to lightly push upward the router so that the top part of the CPD2 holder (or CKD2 for SL version) hitched to the DIN rail get out of this rail and then fold out the top part of the router away from the DIN rail.

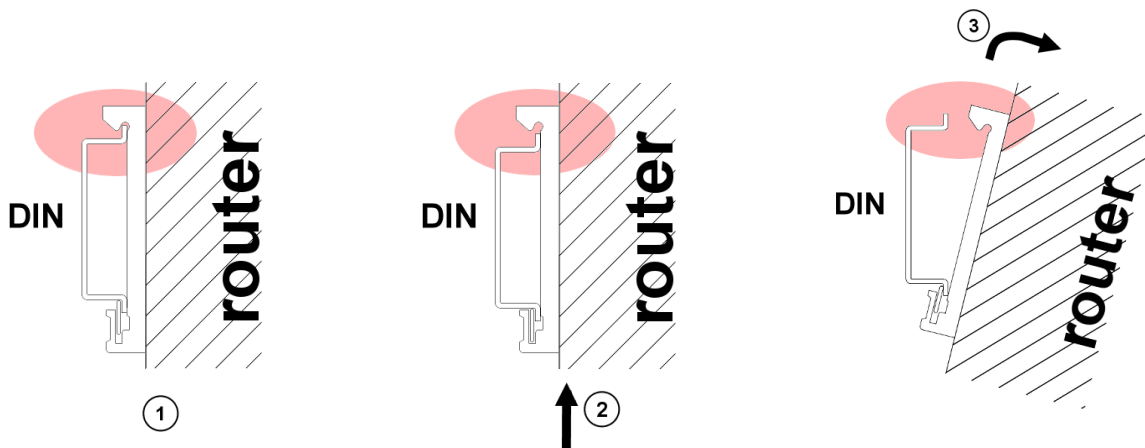

Figure 13: Removing from the DIN rail

## 5.8 Description of the front panel

On the front panel is located:

Caption	Connector	Description
PWR	2-pin	Connector for the power supply adapter.
ETH	RJ45	Connector for connection into the local computer network.
PORT1	RJ45	Connector for expansion port RS232, RS458/422, MBUS, ETHERNET or CNT.
PORT2	RJ45	Connector for expansion port RS232, RS485/422, MBUS, WIFI, WMBUS or SDH.
USB	USB-A Host	Connector for connection of USB devices to the router. Supports devices with PL-2303 and FTDI USB/RS232 converters.
I/O	3-pin	Connector for connection of the binary input and output.

Table 4: Front panel description

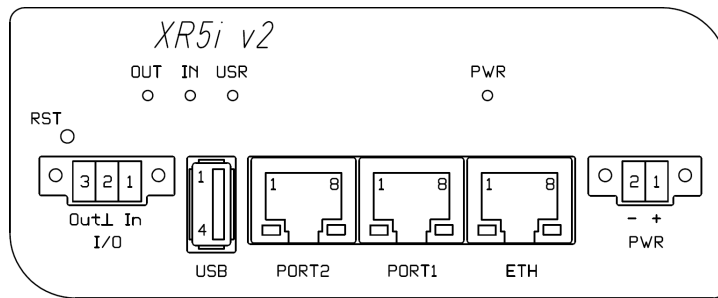

Figure 14: Front panel XR5i v2F

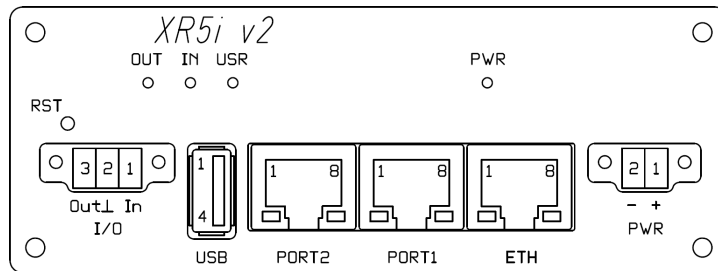

Figure 15: Front panel XR5i v2F SL

### 5.8.1 Status indication

About router status inform four LED indicators on the front panel and on every port are two LED indicators, which inform about port status.

Caption	Color	State	Description
PWR	Green	Blinking On Fast blinking	Router is ready Starting of the router Updating firmware
USR	Yellow	Function selected by user	
OUT	Green	On	Binary output active
IN	Green	On	Binary input active
ETH	Green	On Off	Selected 100 Mbit/s Selected 10 Mbit/s
ETH	Yellow	On Blinking Off	The network cable is connected Data transmission The network cable is not connected
PORT	Green	Depends on the expansion port (see user's guide of used port)	
PORT	Yellow	Depends on the expansion port (see user's guide of used port)	

Table 5: Router status indication

## 5.8.2 Power connector PWR

Panel socket 2-pin.

Pin number	Signal mark	Description
1	VCC(+)	Positive pole of DC supply voltage (+10 to +30 V DC)
2	GND(-)	Negative pole of DC supply voltage

Table 6: Connection of power connector

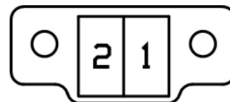

Figure 16: Power connector

Power supply for router is required between +10 V to +30 V DC supply. Protection against reversed polarity without signaling is built into the router.

The power consumption during receiving is 1,6 W. The peak power consumption during data sending is 5,5 W. However, values of consumption can be increased, if some expansion port is equipped. For correct operation it is necessary that the power source is able to supply a peak current of 1 A.



Connector on the power cable connects into the power connector on the router head and tightens locking screws (see figure below).

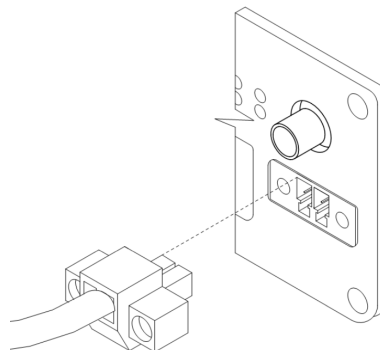

Figure 17: Connection of power supply connector



Circuit example:

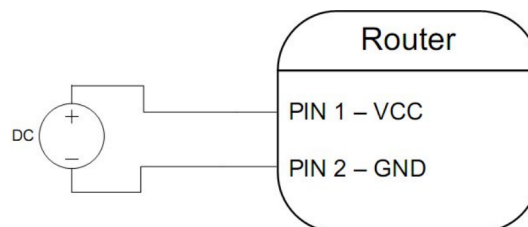

Figure 18: Connection of power supply



The positive pole VCC is marked by a red socket on the power.

### 5.8.3 Ethernet port

Panel socket RJ45.

Pin	Signal mark	Description	Data flow direction
1	TXD+	Transmit Data – positive pole	Input/Output
2	TXD-	Transmit Data – negative pole	Input/Output
3	RXD+	Receive Data – positive pole	Input/Output
4	—	—	
5	—	—	
6	RXD-	Receive Data – negative pole	Input/Output
7	—	—	
8	—	—	

Table 7: Connection of Ethernet connector

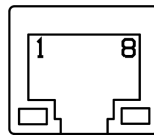

Figure 19: Ethernet connector



**ATTENTION! Port ETH is not POE (Power Over Ethernet) compatible!**

Ethernet cable plug into the RJ45 connector labeled as ETH (see figure below).

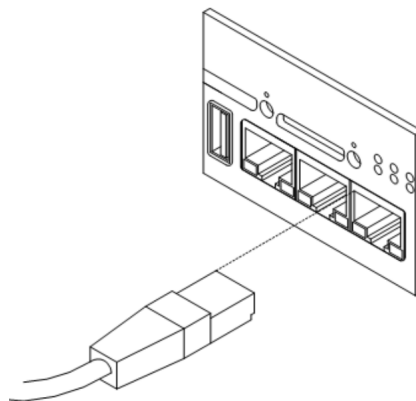

Figure 20: Connection of ethernet cable



Example of the ETH router connection:

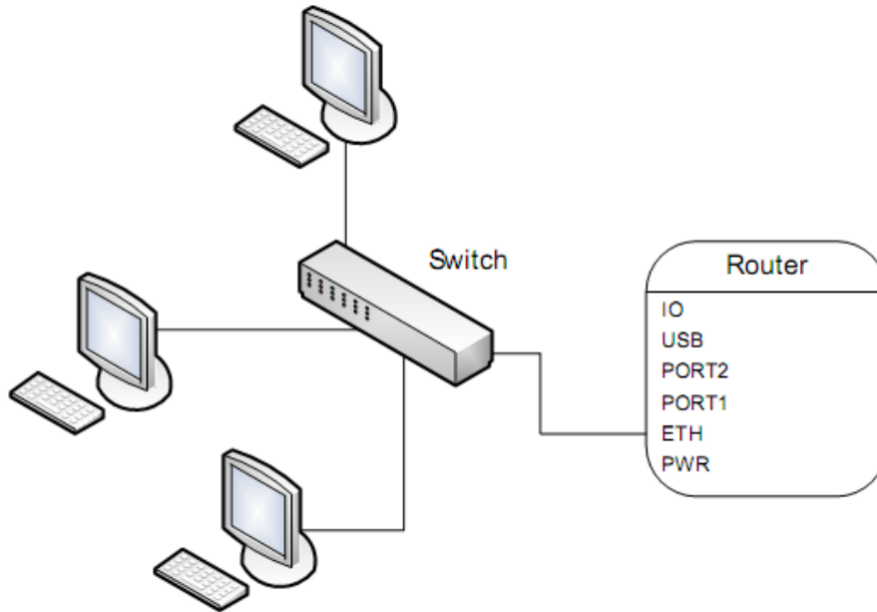

Figure 21: Example of router connection

### 5.8.4 PORT1

The PORT1 is equipped on customer's request with one of the offered expansion ports:

- RS232
- RS485
- RS422
- ETHERNET
- MBUS
- CNT



Description and examples of expansion ports connection can be found in user's guide for corresponding expansion port.

PORT1 cable plug into the RJ45 connector labeled as PORT1 (see figure below).

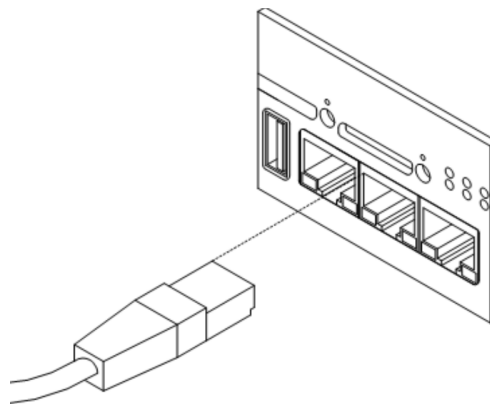

Figure 22: PORT1 cable connection

### 5.8.5 PORT2

The PORT2 is equipped on customer's request with one of the offered expansion ports:

- RS232
- RS485
- RS422
- MBUS
- SDH
- WIFI
- WMBUS



Description and examples of expansion ports connection can be found in user's guide for corresponding expansion port.

PORT2 cable plug into the RJ45 connector labeled as PORT1 (see figure below).

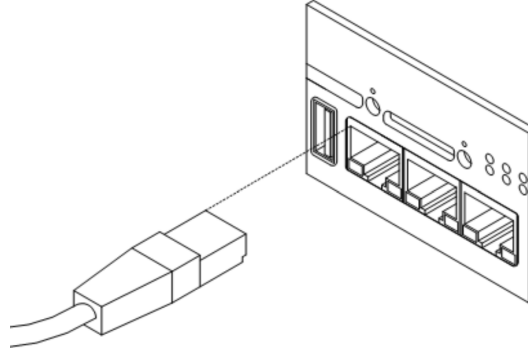

Figure 23: PORT2 cable connection

### 5.8.6 USB Port

Panel socket USB-A.

Pin	Signal mark	Description	Data flow direction
1	+5 V	Positive pole of 5 V DC supply voltage	
2	USB data -	USB data signal – negative pole	Input/Output
3	USB data +	USB data signal – positive pole	Input/Output
4	GND	Negative pole of DC supply voltage	

Table 8: Connection of USB connector



Figure 24: USB connector



Example of connecting devices with serial interface to the USB:

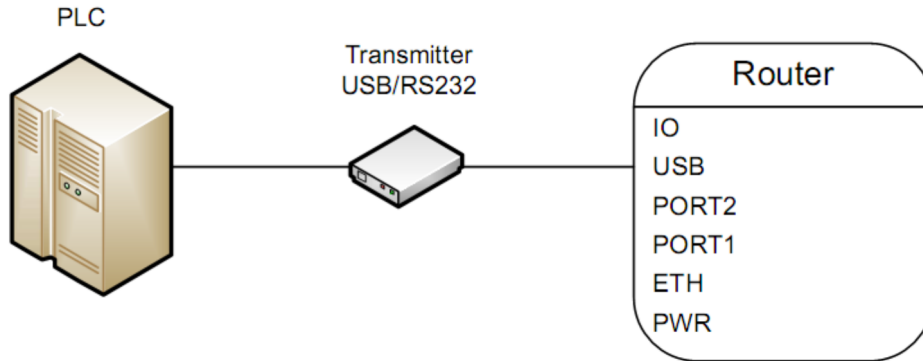

Figure 25: Connection PLC to the router



Example of connecting of USB flash disk to the USB:

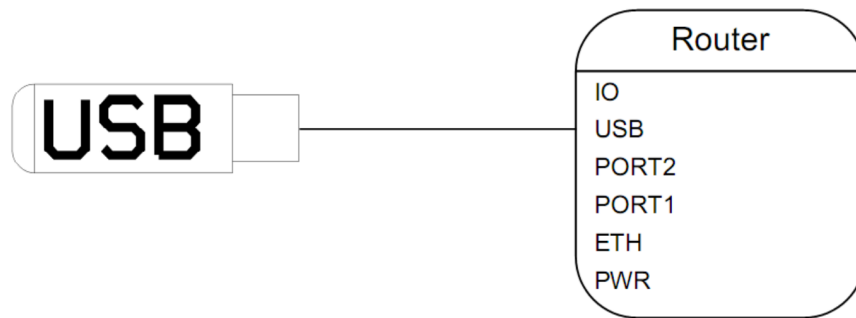

Figure 26: Connection flash memory to the router

### 5.8.7 I/O Port

Panel socket 3pin.

Pin	Signal mark	Description	Data flow direction
1	BIN0	Binary input	Input
2	GND	Signálová zem	
3	OUT0	Binary output	Output

Table 9: Connection of I/O port

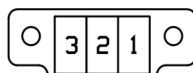

Figure 27: I/O connector

The user interface I/O is for processing of binary input signal and to control (settings) of binary output signal. Binary output is not switched to ground in the default configuration.

Maximum load binary output is 30 V / 100 mA. The constant current supplied by the binary input is 3 mA.

Connector I/O cable connect into the I/O connector on the router head and tighten locking screws (see figure below).

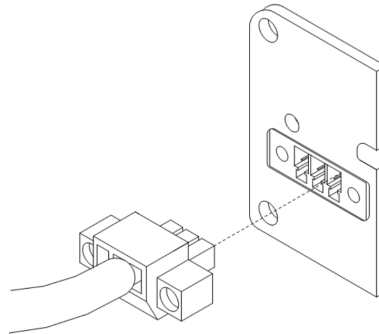

Figure 28: Connection of I/O cable

Circuit example of a binary input or output equipment with router:

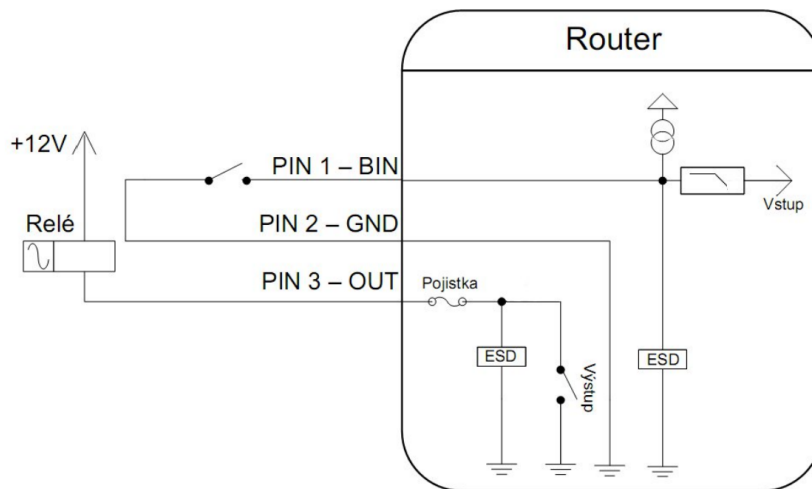

Figure 29: Connection of input and output to the router

### 5.8.8 Reset



It is important to distinguish between reset and reboot the router.

Action	Router behavior	Invoking events
Reboot	Turn off and then turn on router	Disconnect and connect the power, Press the <i>Reboot</i> button in the web configuration
Reset	Restore default configuration and reboot the router	Press RST button

Table 10: Description of reset and restart router

After green LED starts to blink it is possible to restore initial settings of the router by pressing button RST on front panel. After press button RST it is restoration of default configuration and reboot (green LED will be on).



For pressing the RST button could be used a narrow screwdriver.

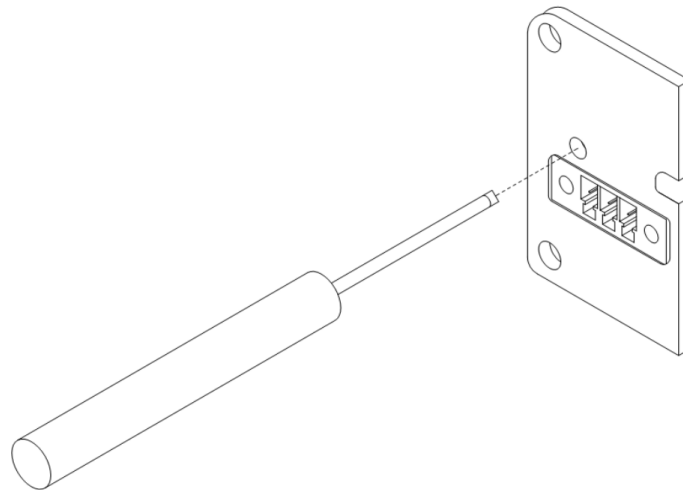

Figure 30: Router reset



We recommend to backup your router configuration (see Configuration manual), because after reset router set configuration to the initial state.

# 6. First use

## 6.1 Connecting the router before first use

Before you give up the router, it is necessary to connect all components needed for the operation of your applications and the SIM card must be inserted (see figure below).



The router can not operate without connected power supply.

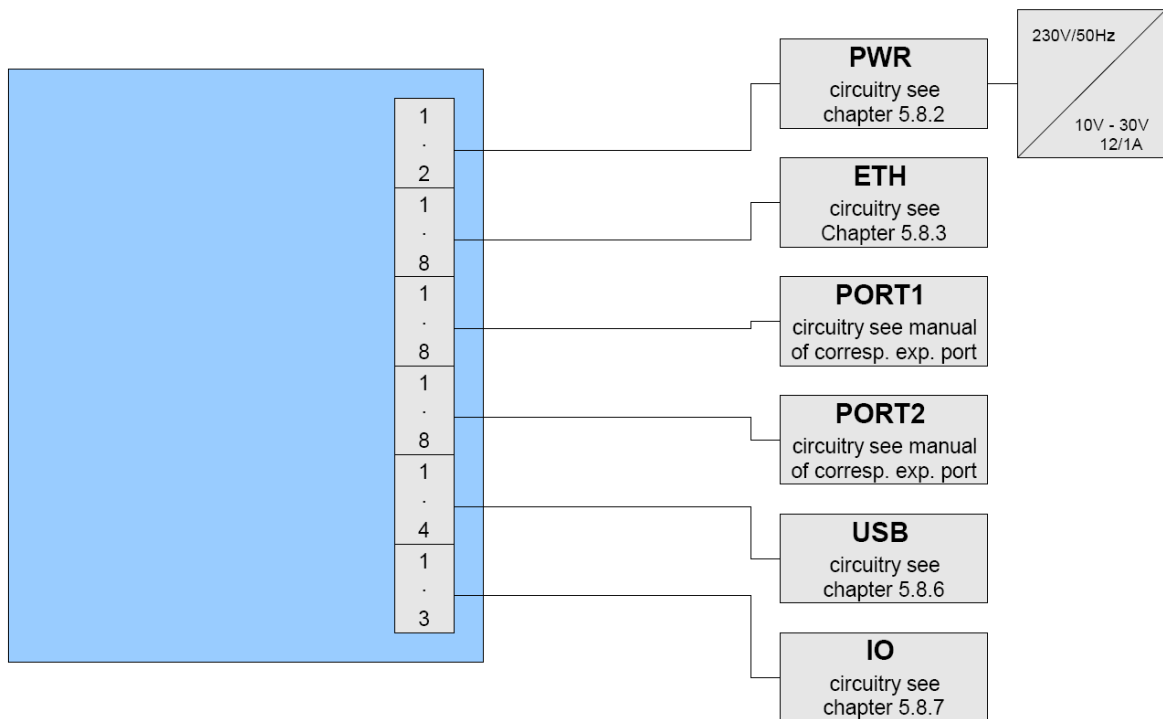

Figure 31: Router connection

## 6.2 Start

The router is set up connecting the power supply to the router. The behavior of the router can be modified by means of the web or Telnet interface, which is described in the configuration manual.

The power consumption during receiving is 1,6 W. The peak power consumption during data sending is 5,5 W. However, values of consumption can be increased, if some expansion port is equipped. For correct operation it is necessary that the power source is able to supply a peak current of 1 A.

## 6.3 Configuration

### 6.3.1 Configuration over web browser

Monitoring of the status, configuration and administration of the router can be performed by means of the web interface, which is available after insertion of IP address of the router into the web browser. The default IP address of the router is 192.168.1.1. Configuration may be performed only by the user "root" with initial password "root".



A detailed description of the router settings via the Web interface can be found in the configuration manual.

### 6.3.2 Configuration over Telnet

Monitoring of status, configuration and administration of the router can be performed by means of the Telnet interface. After IP address entry to the Telnet interface it is possible to configure the router by the help of commands. The default IP address of the router is 192.168.1.1. Configuration may be performed only by the user "root" with initial password "root".



A detailed description of the router settings via the Telnet interface can be found in the configuration manual.

# 7. Technical parameters

## 7.1 Technical parameters of router

<b>XR5i v2</b>		
Complies with standards		ETSI EN 301 489-1 V1.8.1, EN 60950-1:06 ed.2 + A11:09 + A1:10
Temperature range	Function Storage	-30 °C to +60 °C -40 °C to +85 °C
Protection	Freely In switch board	IP20 IP56
Supply voltage		10 to 30 V DC
Consumption	Without communication Communication	1,6 W to 5,5 W
Dimensions		42 x 76 x 113 mm (DIN lišta 35 mm)
Weight		XR5i v2 – 150 g XR5i v2 SL – 280 g
User interface	ETH USB PORT1 PORT2	Ethernet (10/100 Mbit/s) USB 2.0 Ethernet (10/100 Mbit/s) On customer's request

Table 11: Technical parameters of router

## 7.2 Technical parameters of processor

<b>32b ARM mikroprocesor</b>	
Memory	512 Mb DDR SDRAM 128 Mb FLASH 1 Mb MRAM
Interface	Serial interface RS232 Ethernet interface 10/100 Mbit/s USB 2.0 interface

Table 12: Technical parameters of processor

### 7.3 Technical parameters I/O port

I/O port		
Input/Output	Binary input Binary output	Reed contact with trigger level 1,3 up to 1,4 V 100 mA / max. 30 V

Table 13: Technical parameters I/O port

### 7.4 Technical parameters of expansion port

Technical parameters of the expansion ports are specified in separate manuals for expansion ports.

## 8. Recommended literature

- [1] Conel: **Start guide,**
- [2] Conel: **Configuration manual,**
- [3] Conel: **User's manual – Expansion port RS232,**
- [4] Conel: **User's manual – Expansion port RS485/RS422,**
- [5] Conel: **User's manual – Expansion port MBUS,**
- [6] Conel: **User's manual – Expansion port CNT,**
- [7] Conel: **User's manual – Expansion port ETH,**
- [8] Conel: **User's manual – Expansion port WIFI,**
- [9] Conel: **User's manual – Expansion port WMBUS,**
- [10] Conel: **User's manual – Expansion port SD,**
- [11] Conel: **Application guide – Expansion port mounting,**
- [12] Conel: **Application guide – Programmer guide.**

## 9. Possible problems



Some network cards are able to be set in situation, when it is not possible to connect the router. It is possible to solve this problem in the following steps:

- hand by selection communication rates 10 MB/s in property network cards,
- connect router over switch,
- start computer only after finalizing the start of the router.

## 10. FAQ

 I can't get from internet on equipment, which is connected to router and I have NAT enabled.

- *The device's gateway has to be configured as the router.*

 Router resets itself, connection on Ethernet fails.

- *It is necessary to use an antenna, which will be situated far from power supply.*

 I don't get on web server at NAT.

- *The remote http access of the router has to be disabled, default server address has to be your web server and the gateway of the web server has to be the IP of router.*

 Connection fails on Ethernet or connection isn't establishing.

- *On ethernet interface of the router it is possible to switch auto negotiation off and set a rate and duplex by hand.*

 DynDNS not function.

- *In private APN not functional.*
- *If the same IP address is recorded in your canonic name as dynamically assign address, it means that the operator is using NAT or firewall.*
- *NAT is possible to verify by the help of the ping on address of your server with static IP address and by the help of the router address verify and address in ping.*
- *Firewall is possible to verify, for example by remote access on web interface.*
- *The operator doesn't give out address DNS servers and without DNS server's it is impossible to connect to server dyndns.org. In log system will be this message:*
  - *DynDNS daemon started*
  - *Error resolving hostname: no such file or directory*
  - *Connect to DynDNS server failed*

 IPsec tunnel is establishing but communication doesn't function.

- *Probably it is badly set up route conditionals of connected equipment or it is bad set up GW.*

 FTP doesn't function.

- *Router doesn't support the active FTP mode, supports the passive mode only.*

 RS232 doesn't function.

- *It is necessary to verify present the expansion port RS232.*
- *Verify present the expansion port RS232 in router configuration in menu „external port“, or verify connection locally by the help Telnet-Hyper terminal.*

 L2TP or IPSec isn't establishing.

- *Verify the reason in the log system.*

# 11. Customers support

You can find current information about this product on our website:

[www.conel.cz](http://www.conel.cz)



## Upkeep-advice:

- During cleaning of the router do not use aggressive chemicals, solvents and abrasive cleaners!

Conel Company hereby declares that the router narrated in this user's guide fits all basic demands of directive 1999/5/EC (R&TTE).

Router fits values of coefficient SAR defined by association ICNIRP and values of "About protection of health before non-ionized radiation".



Declaration of conformity was issued and it is possible to find it on the enclosed CD or at producer.